



FDC40

Fire damper, round, damper blade 40 mm
CE marked in accordance with EN 15650:2010
Tested in accordance with EN 1366-2
Classified in accordance with EN 13501-3
LUKA C/ATC 3

Available types

F D C 40 - - -

- F** fire-resistant
- D** damper
- C** round
- 40** damper blade thickness 40 mm

- Mounting frame

- O** none
- MF2** mounting frame 2

- Operation

Manual

- R** without end switches
- RS** with end switches
- EMS-S** with solenoid 24/48 VDC and end switches, magnetic with a supply, (information available on request)

Motor-operated

- M24S** Belimo 24V
- M230S** Belimo 230V
- M24S-ST** Belimo 24V plug-and-play for connection to Belimo supply and/or communication modules

- EX** ATEX classified Schischek 230/24V servomotor explosion-safe (information available on request)

- Accessory

- O** none
- UG** smoke sensor (cannot be used in combination with operating option R, RS, EMS-S or EX)

SA-Select

Check [SA-Select](#) to create extended order codes and selection details online. **NB!** At this moment, SA-Select is only available in Dutch. But it is possible to create extended order codes and selection details online.

Use

The round fire dampers type FDC40 can be used in fire and smoke-separating walls and floors. If they are incorporated in accordance with the instructions, there is a fire resistance of up to 120 minutes depending on how they are built in. The fire dampers have two standard inspection openings. For rapid fitting, the damper is available with a pre-fitted mounting frame. A smoke sensor is available as an optional accessory. For the classification list and the corresponding installation instructions, please see the manual on our website. Certified use requires compliance with the installation instructions in the [manual](#).

Characteristics

- Available in dimensions of \varnothing 355 to 800 mm.
- Fitting can be horizontal or vertical, in any flow direction.
- Two standard round inspection openings of 39 mm.
- Airtightness class C over the housing in accordance with EN1751 (LUKA C) ATC3.
- Airtightness class 3 over the damper blade in accordance with EN1751.
- Hygiene certificate in accordance with VDI 6022.

Finish

- | | |
|---------------|---------------------------------|
| Housing: | galvanised sheet steel |
| Damper blade: | heat-resistant, thickness 40 mm |
| Fusible link: | 72 °C |

Optional (information available on request)

- Galvanised sheet steel with internal and external powder coating.
- Stainless steel EN1.4301/EN1.4401/EN1.4404 (AISI 304/316/316L).
- Stainless steel EN1.4301/EN1.4401/EN1.4404 (AISI 304/316/316L) with internal and external powder coating.
- Motor-operated version with 95 °C fusible link.
- Belimo supply and/or communication module BKN-230-24-MOD.
- For other versions, please ask our sales department.

Classified in accordance with EN 13501-3

For a full classification overview with the various sealing methods, we refer to the manual.

Dimensions

Manual

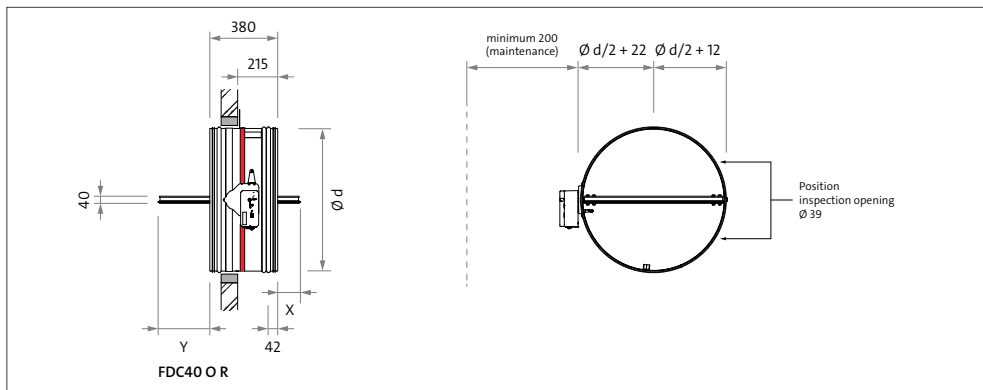

Motor-operated

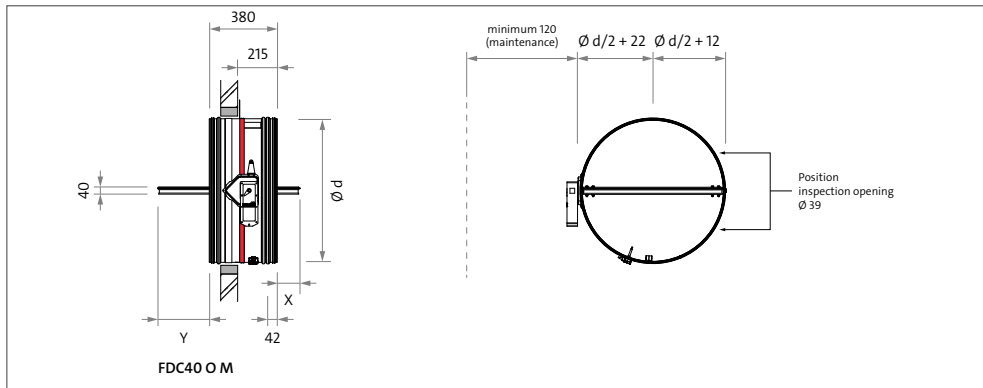

Dimensions

Mounting frame 2

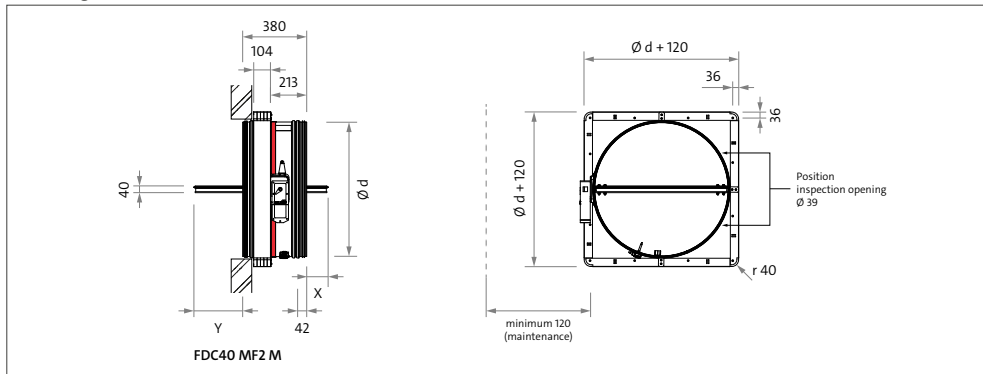

Smoke sensor

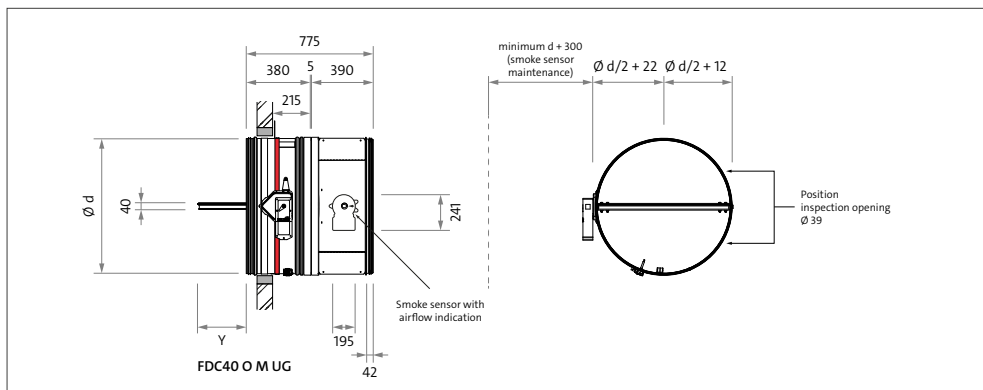

Available dimensions

model	d	free passage in m ²	X	Y	g
355	353	0.0833	-	68	11.9
400	398	0.1079	-	90	13.5
450	448	0.1391	-	115	15.4
500	498	0.1741	-	140	17.5
560	558	0.2301	10	170	20.2
630	628	0.2836	45	205	23.6
710	708	0.3642	85	245	27.7
800	798	0.4668	130	290	33.7

X, Y = protruding length of the damper blade.

g = weight in kg (manual version without mounting frame).

For more specific information about the dimensions or weights per model, we refer to the [manual](#).

Comments

- The dimensions are in mm.
- Please visit our website to download the [manual](#), [declaration of performance \(DoP\)](#) and the [verification certificate of the declaration of performance](#).

Fitting

Installation of the fire damper must be carried out according to the manual.

Points of attention for the installation of fire damper/ smoke sensor combination

Check the airflow direction when applying the fire damper/smoke sensor combination and verify the placement of the combination based on the criteria of NEN EN 6075. Install the combination, as supplied in one piece, so that the air flows through the smoke sensor first and then through the fire damper. Take into account a straight intake length of 5 x Dhydraulic for the smoke sensor, based on the size of the smoke sensor.

This duct section for the smoke sensor must be made in the size of the smoke sensor. After installation, check whether the air direction indication on the smoke sensor corresponds with the direction of the air flow.

In situations where it is not possible to pass the air over the smoke sensor before it flows over the fire damper (think of a supply duct that comes out of a shaft), one can detach the smoke detector section from the fire damper and place it in an alternative position.

It is necessary to take into account:

- The regulations from NEN EN 6075.
- The required approach conditions of 5 x Dhydraulic before the sensor and 3 x Dhydraulic after the sensor.
- The channel between the fire damper and smoke sensor must be a closed section without T-pieces or branches/openings that could affect the measurement/smoke density.

For more detailed information, we refer to the [manual](#).

For good accessibility of the control mechanism/servomotor, a free space of about 300 mm is recommended.